

Presentation of the activities to be performed by

Solar*Tec AG

Task 3.1.1 Fabrication of 3 point focus modules with the starting technology

Efficiency at total system level (BOS)

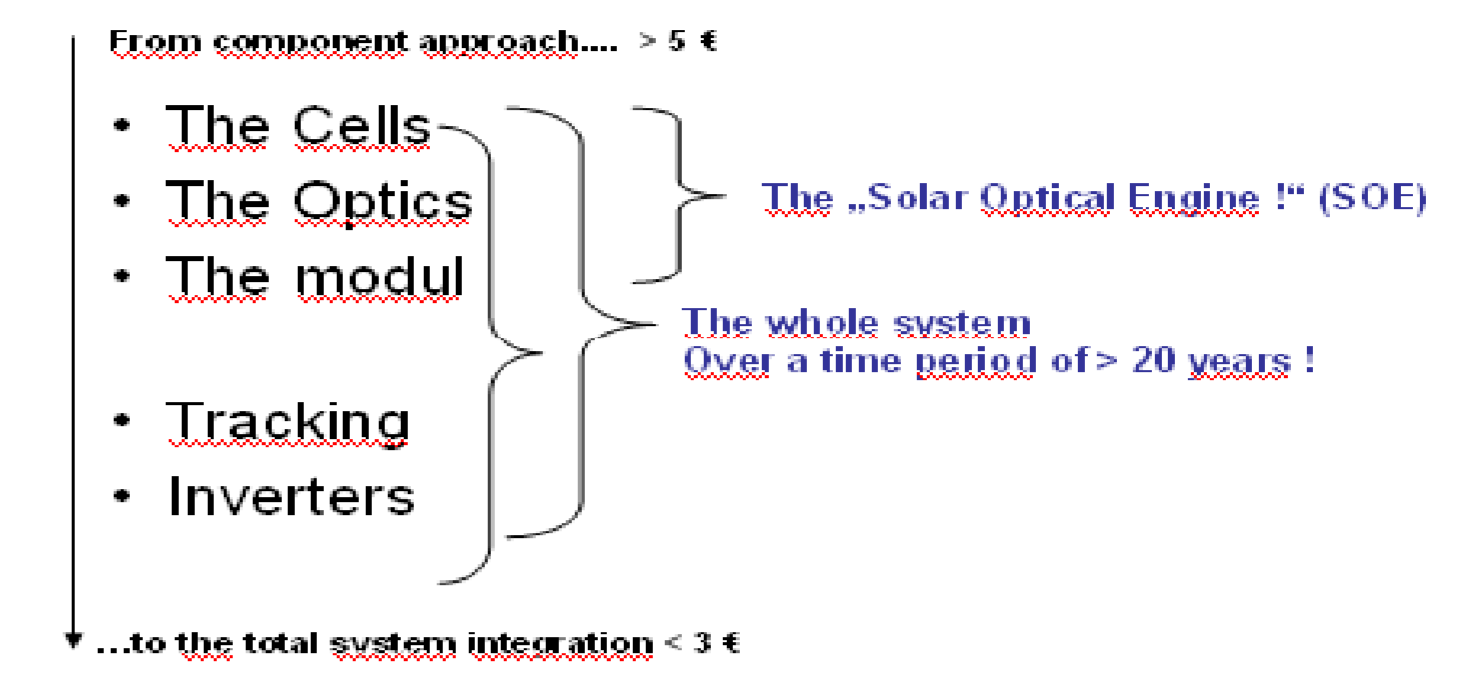

Assembly of the solar cells on the receiver

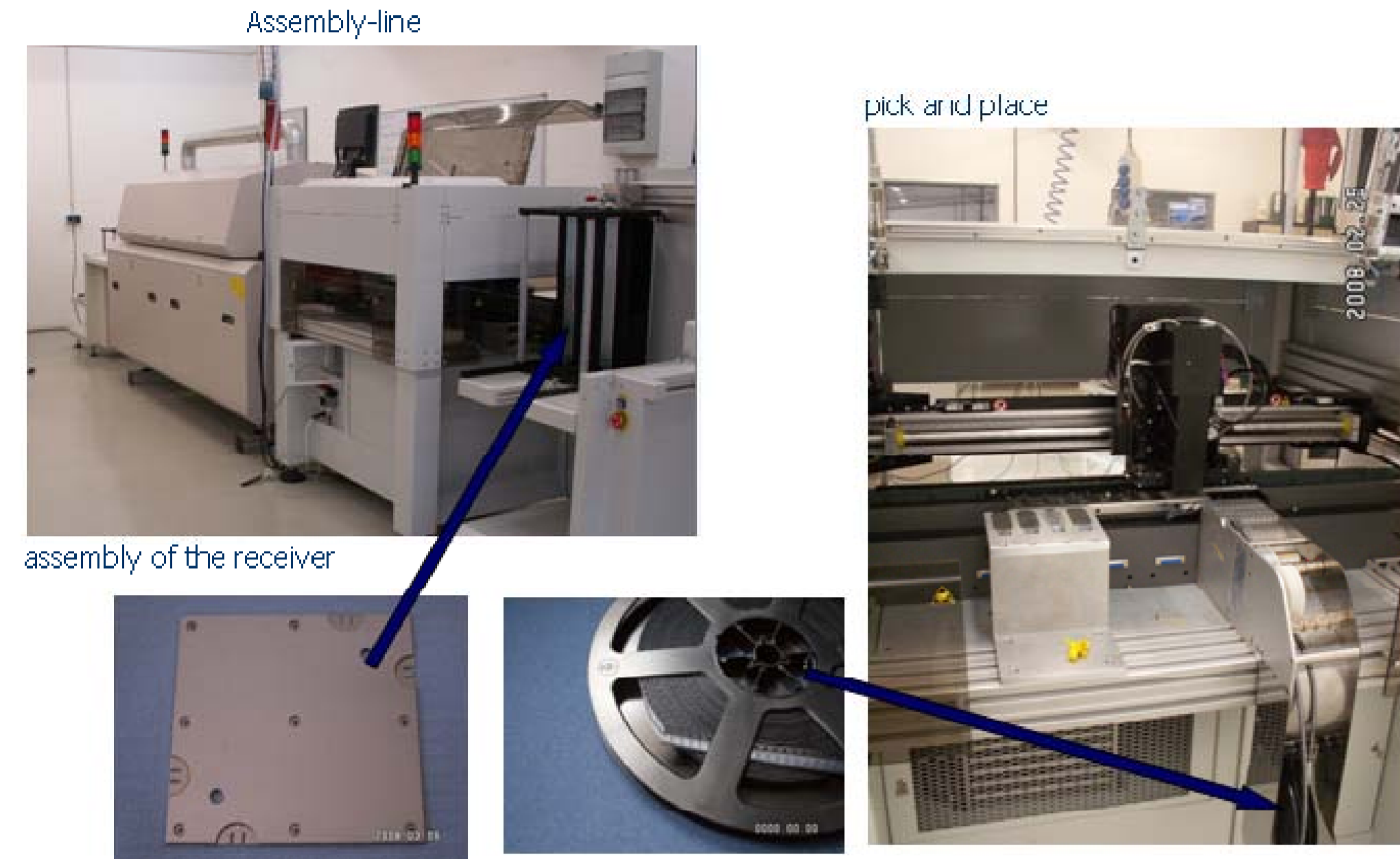

Inline head wedge bonding

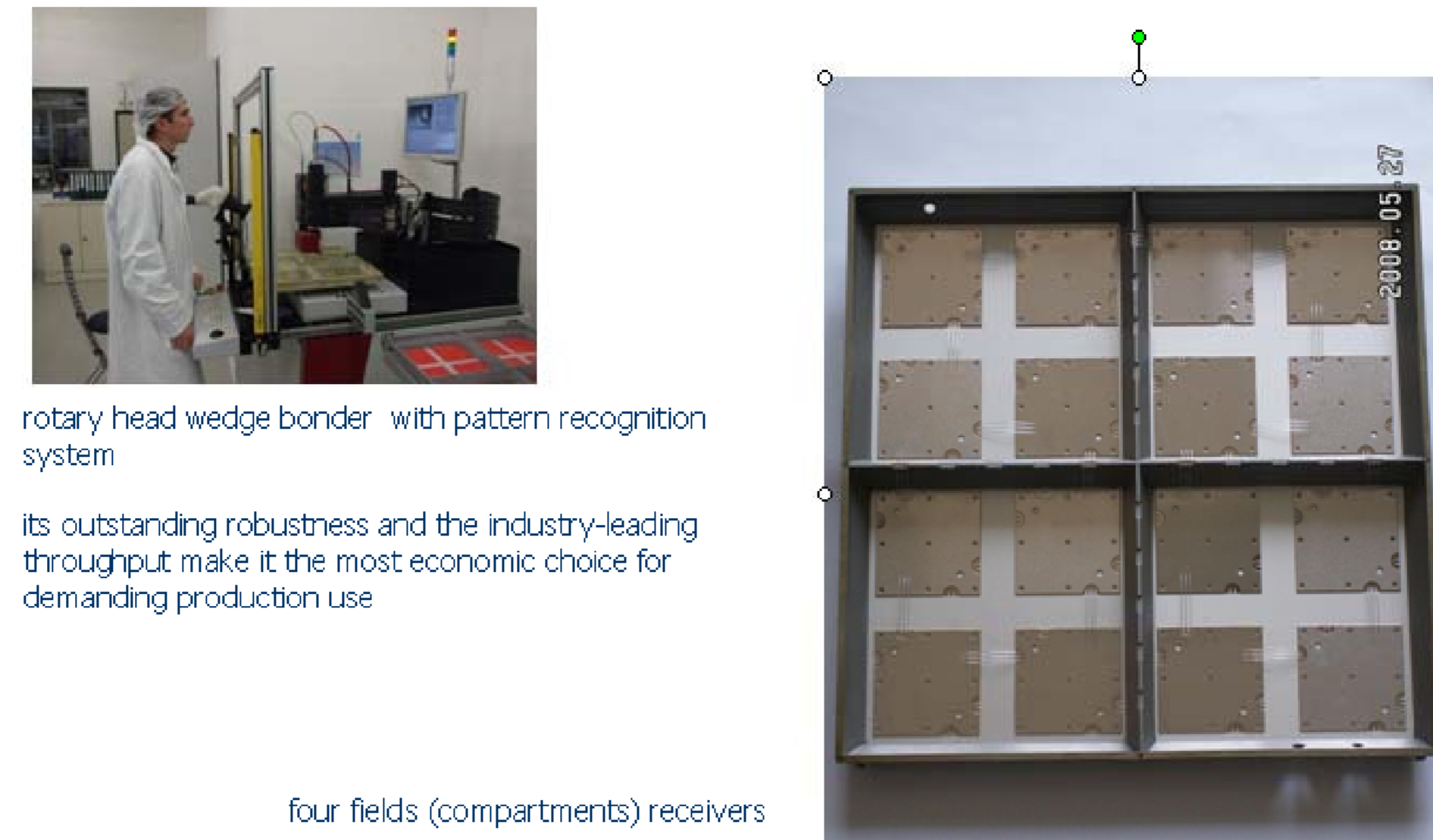

Flasher for modules

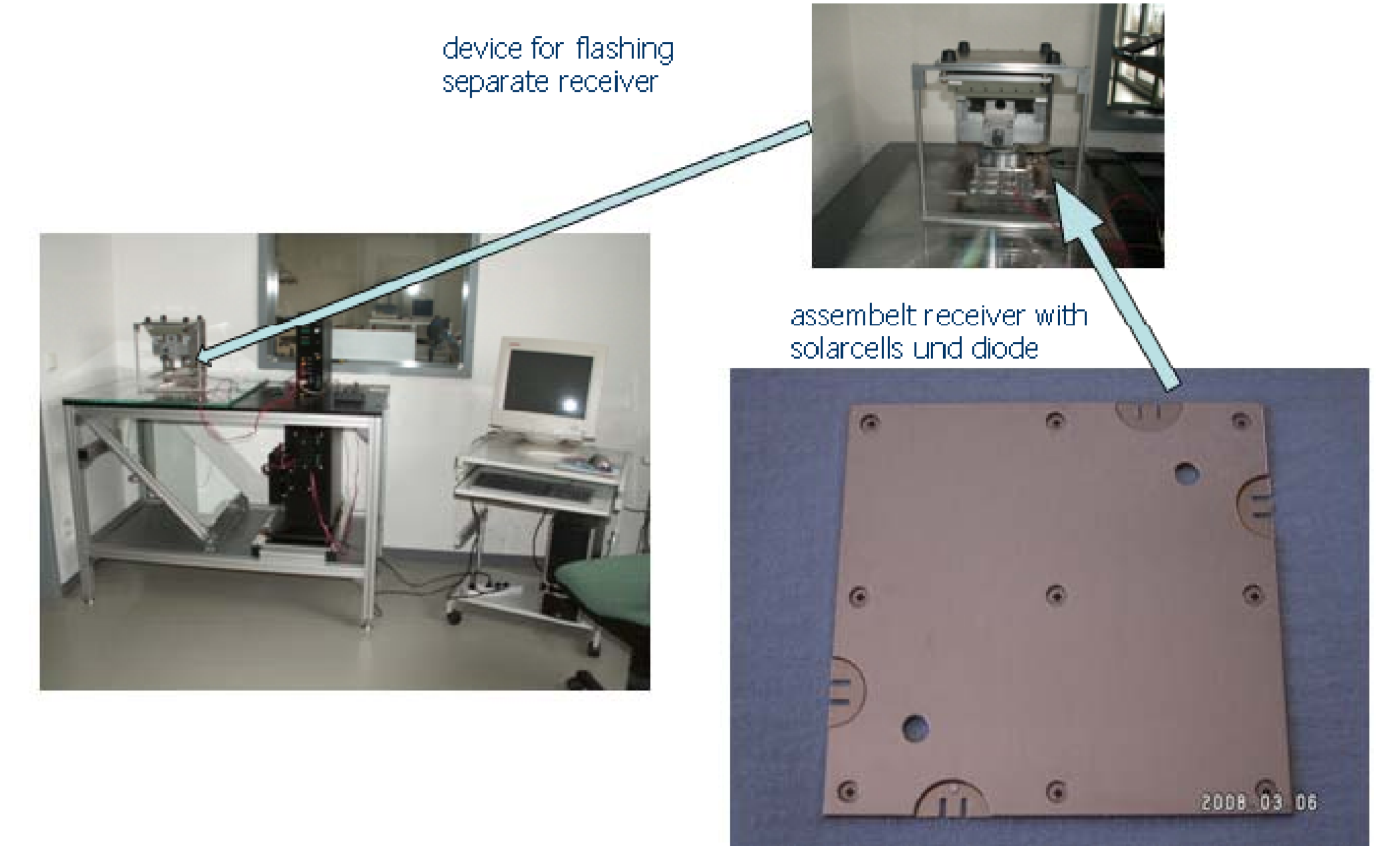

Task 3.1.2 Development of secondary optics to increase the acceptance angle of Fresnel- and Hybrid lenses

Task 3.1.3 Optimization of Fresnel-lens to increase optical efficiency

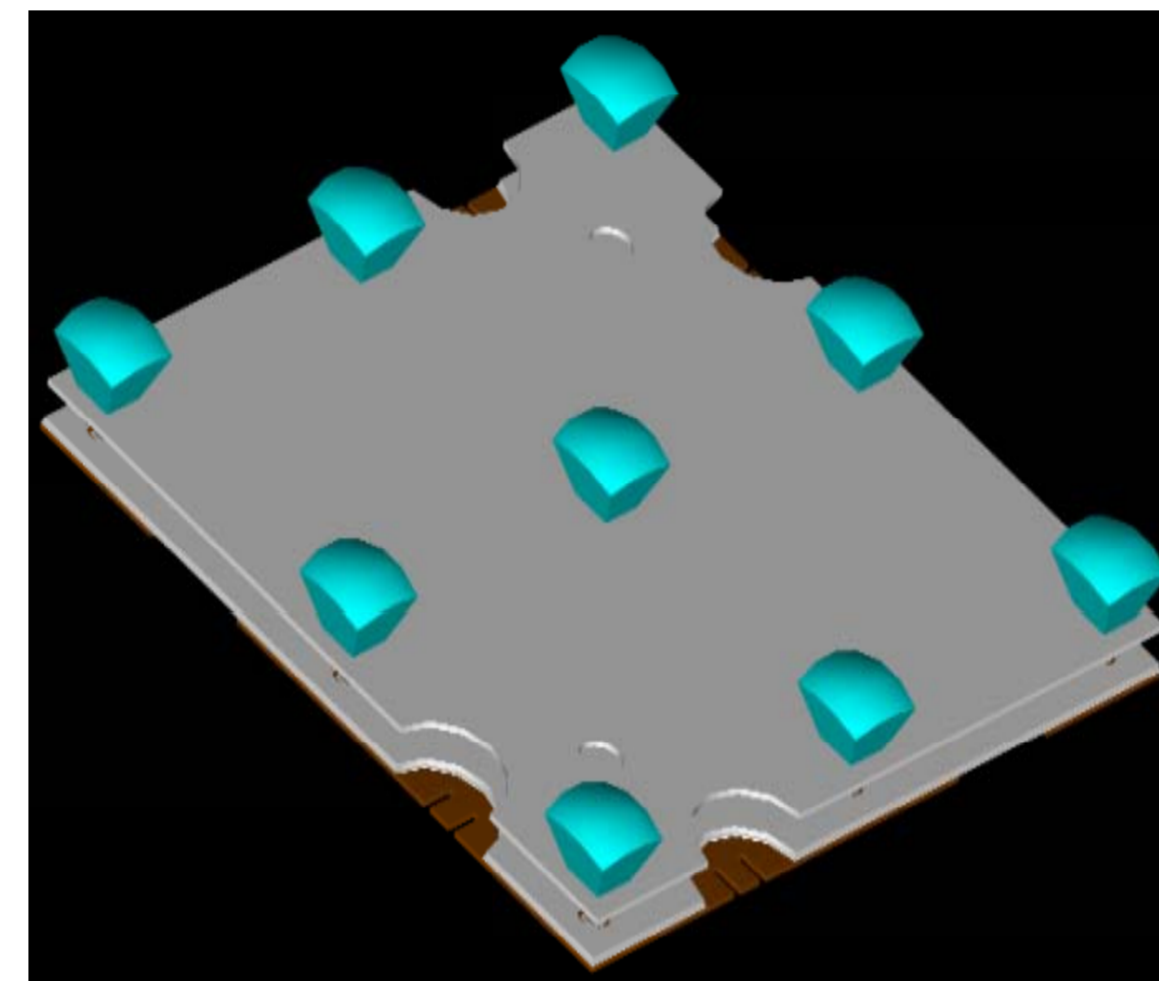
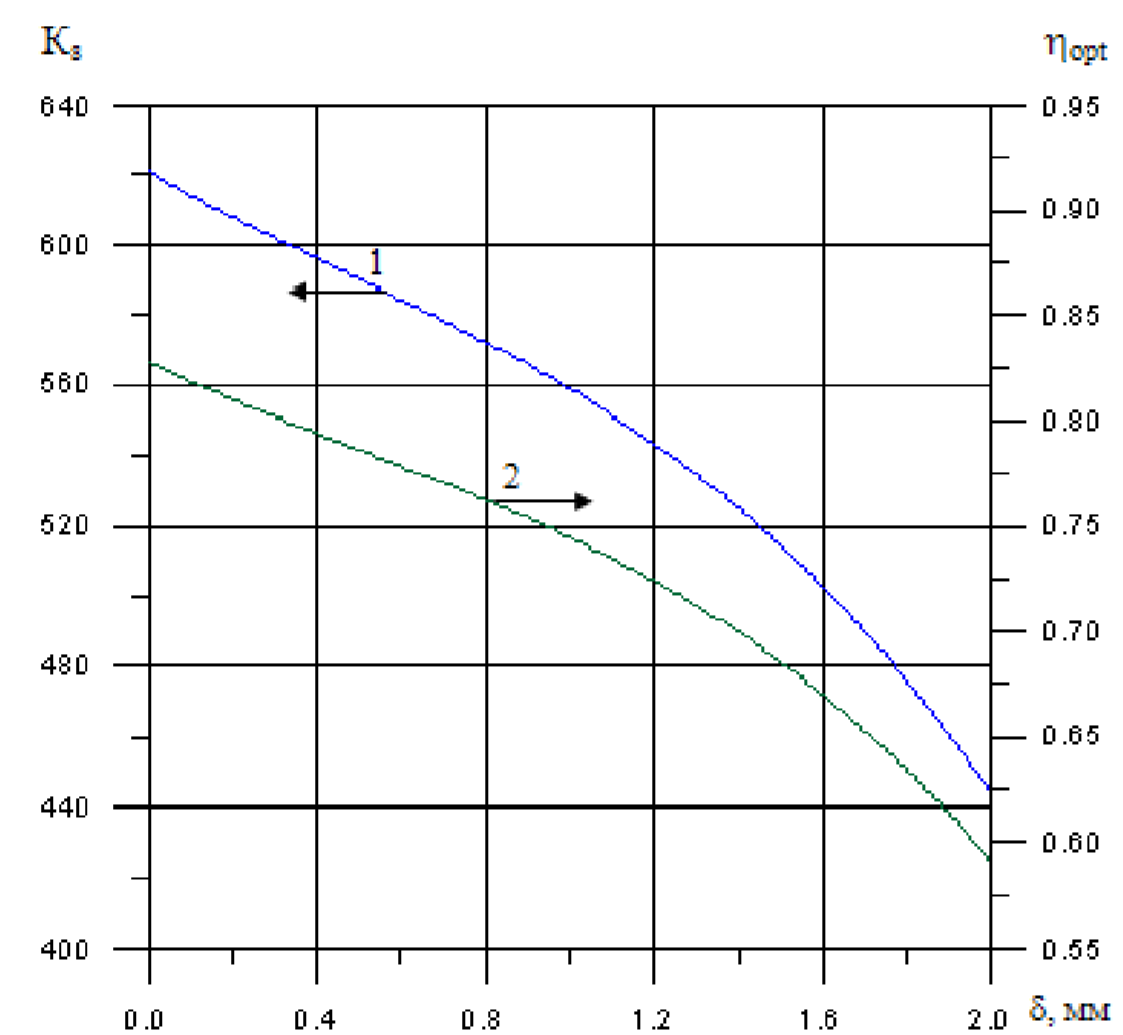
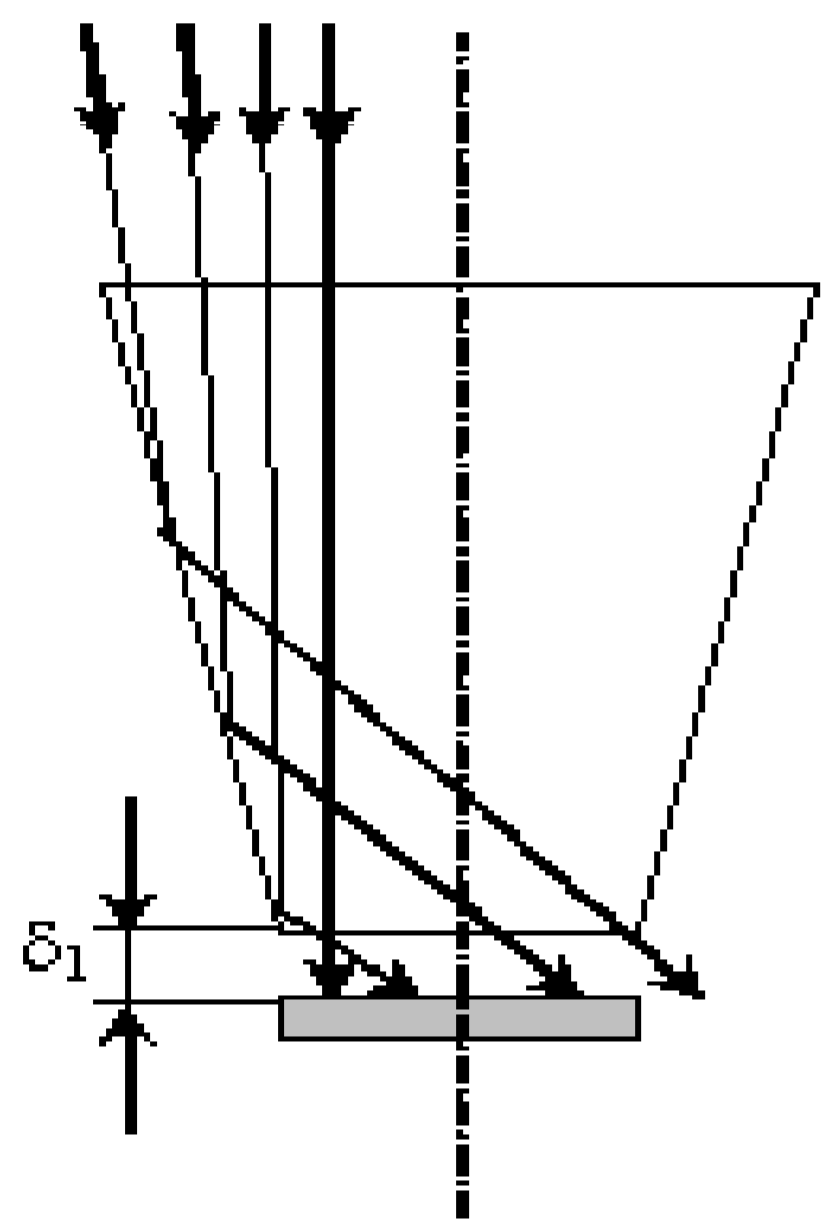

Ideal and counted Fresnellenses and real structure

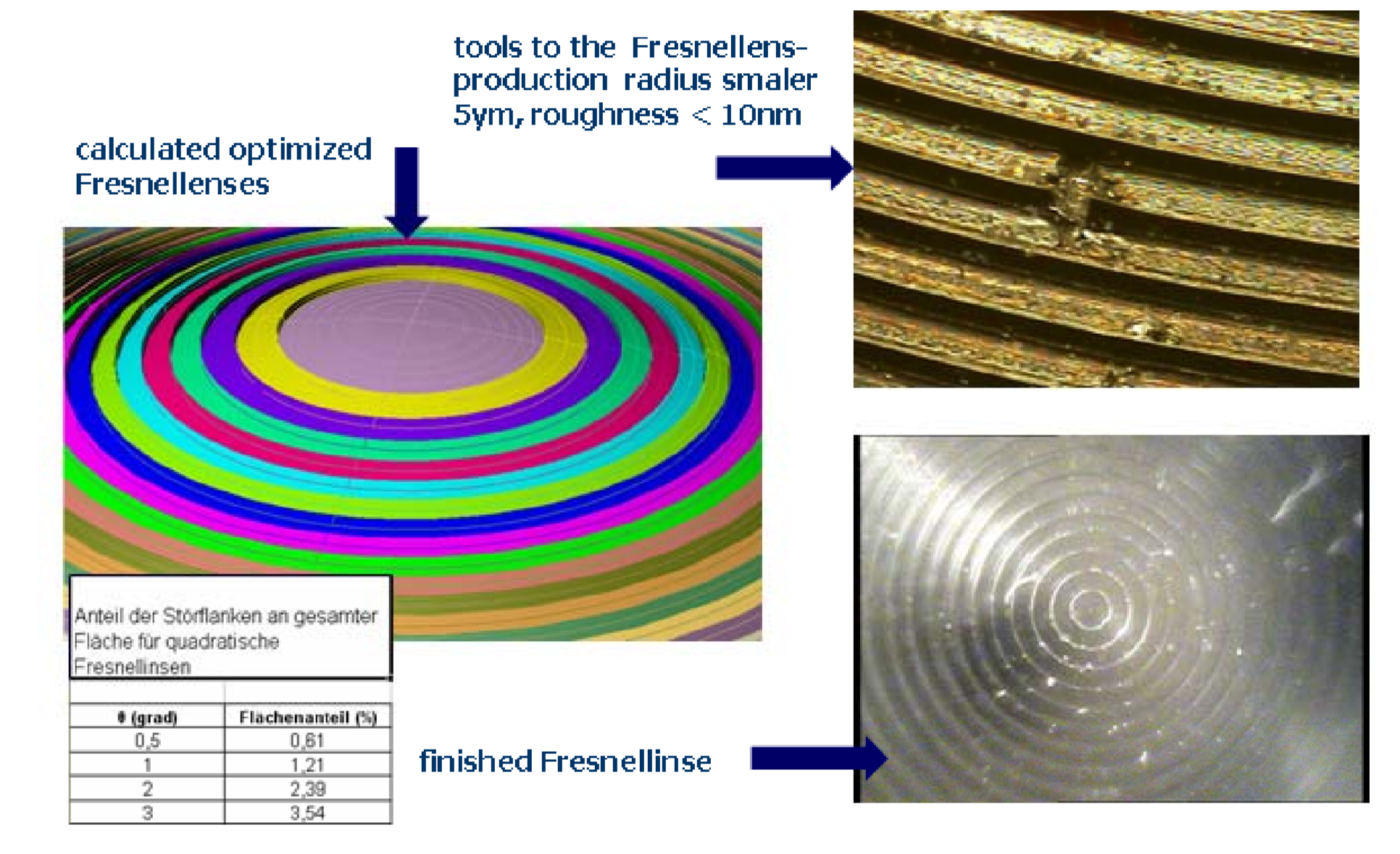

Task 3.1.5 High-throughput assembling optimization (cell positioning, wire connections, sealing process, encapsulation material, replacement of metal heat sink)

Task 3.1.6 Realization of optimized Point focus receivers

Cells und Fresnellinsen to each other aligned

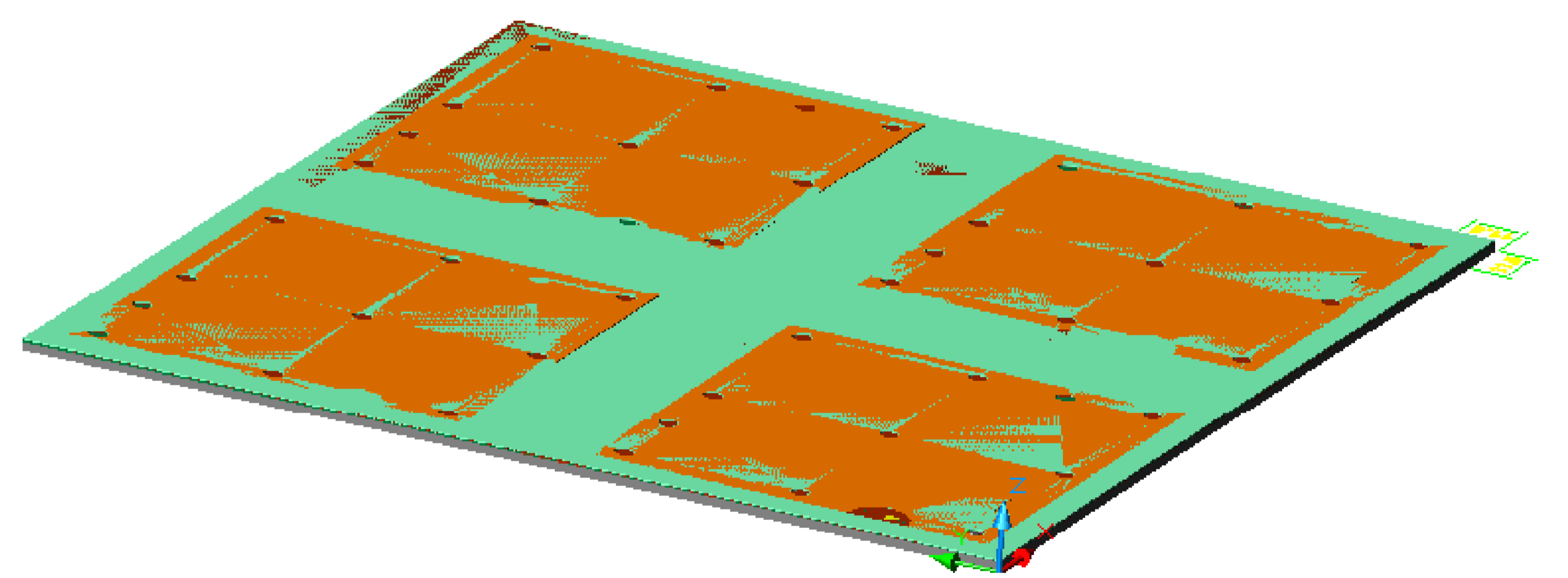
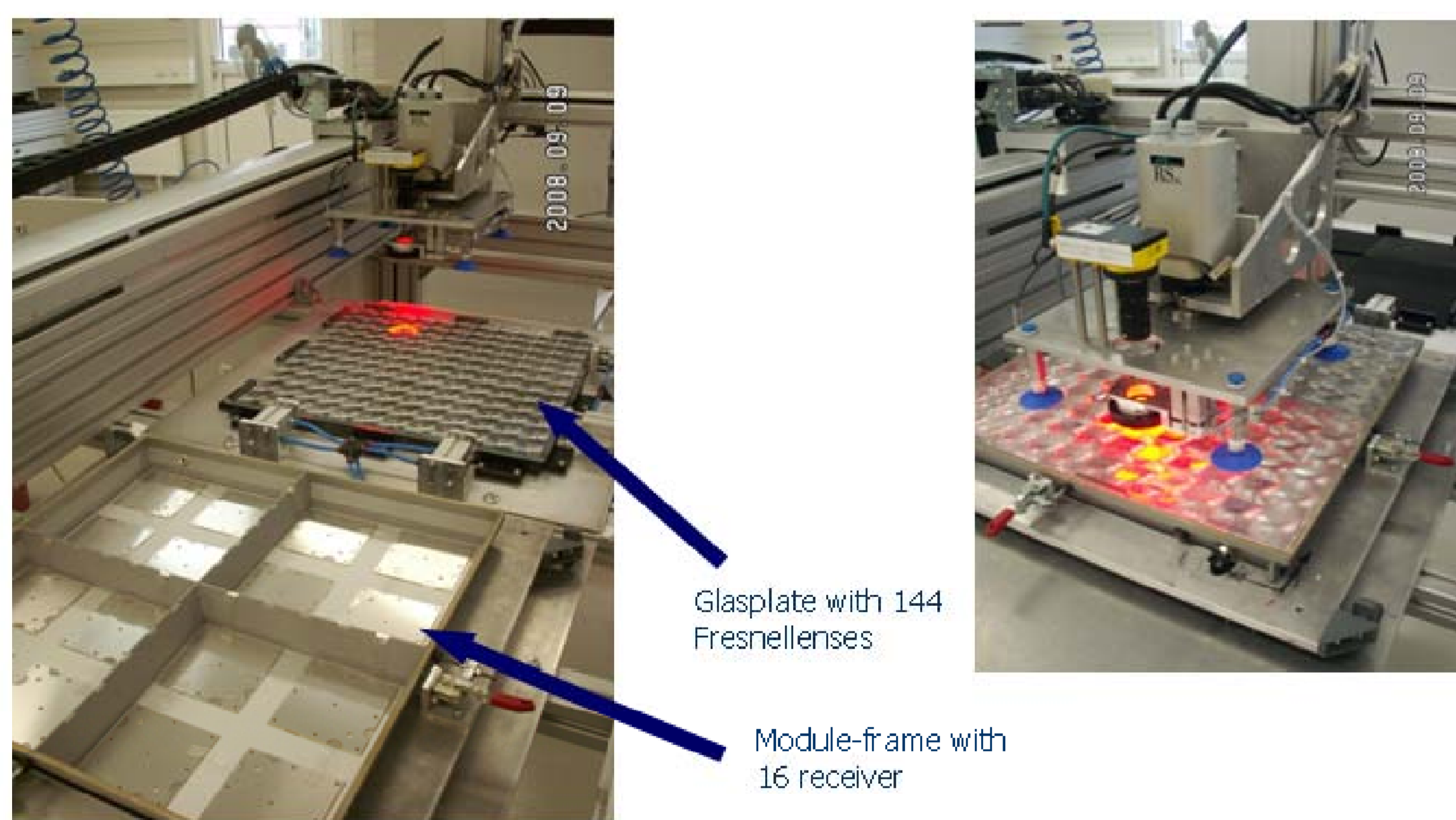

Task 3.1.8 Development and adaptation of a reliable and accurate tracking for Point focus systems (Solar*Tec, Robotiker)

Tracker controller-system

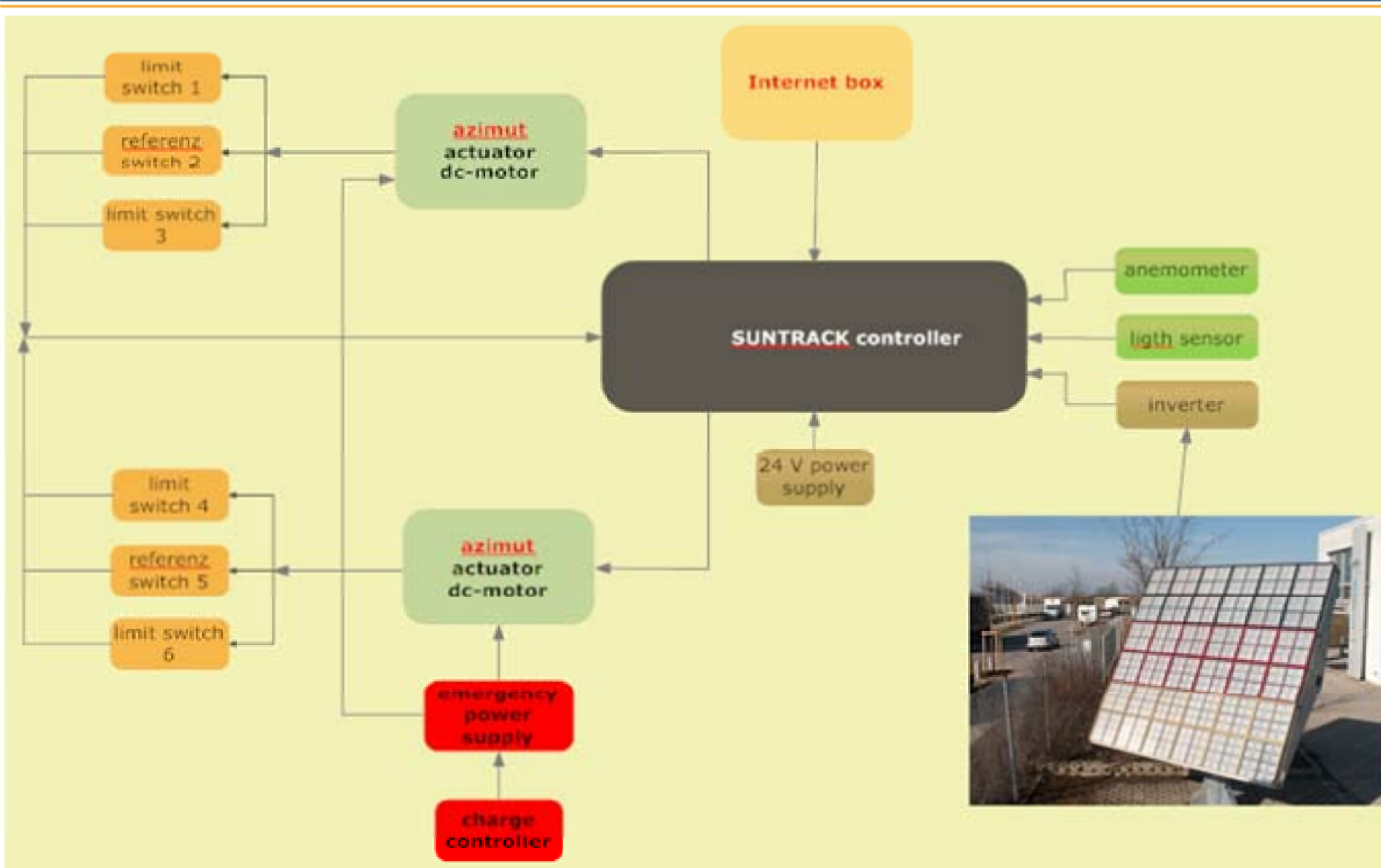

Control by astronomical calculation and light sensor



Specification for Tracker and controller:

- accuracy of tracking = 0,1°
- azimuth movement 270°
- elevation movement 80°
- operational reliability and safety against gusts and wind speed of 40 m/s = 144 km/h
- operating temperature: -20° to 85°
- relative humidity: 95%

